

DESIGN AND SPECIFICATIONS

HEAR AND EXPERIENCE THE DIFFERENCE





CONTENT

PIPE AND FITTING DESIGN	4
TECHNICAL PROPERTIES	5
APPLICATION AREAS	6
ACOUSTIC PERFORMANCE	8
FIRE SAFETY	12
PRODUCT OVERVIEW	14

PIPE AND FITTING DESIGN

PIPELIFE Master3Plus acoustic soil and waste pipe systems comprise three carefully matched layers that are engineered to achieve specific properties.

PIPE DESIGN

SMOOTH INNER LAYER

Made of polypropylene copolymer (PP-CO)

SOLID MIDDLE LAYER

Made of mineral-reinforced polypropylene (PP-MV)

IMPACT-RESISTANT OUTER LAYER

Made of polypropylene copolymer (PP-CO)

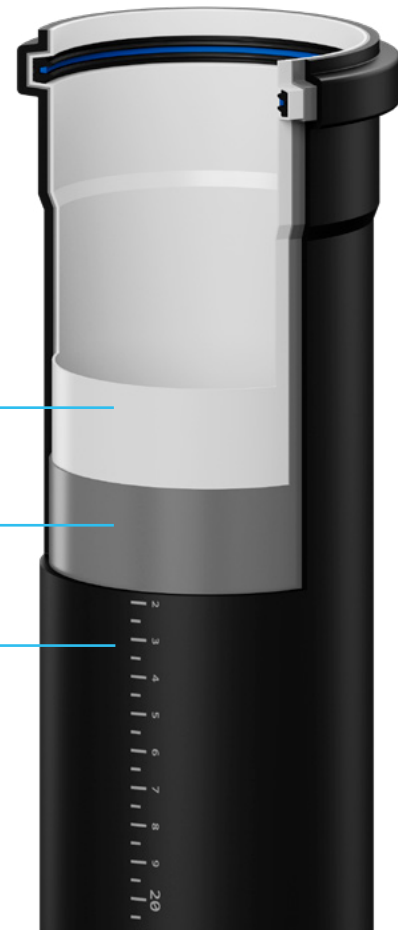

FITTING DESIGN



SOCKET-SPIGOT AND ALL-SOCKET FITTINGS

Molded plug-in sockets, factory fitted sealing ring. Made of mineral-reinforced polypropylene (PP-MV).



HYDRAULICALLY OPTIMIZED DESIGN

Reduced turbulences, higher flow rate. Increased number of connections to downpipe.



INCREASED PRODUCT WEIGHT AND WALL THICKNESS

Superior sound insulation.

TECHNICAL PROPERTIES

APPLICATION CLASS

Tested and approved for soil and waste discharge for application area code „BD“ in accordance with EN 1451-1; with diameters ≥ 75 mm permitted also for underground discharge systems up to the main sewer junction.

MATERIAL

Pipe: PP-CO/PP-MV/PP-CO

Fitting: PP-CO-MV, S16
tested to EN 1451-1

Gasket: EPDM

All products are free from halogens, cadmium and heavy metals

TEMPERATURE RESISTANCE

Long-term temperature load max. 95 °C
(temperature change test according to EN 1451-1)

Continuous load 60 °C

INSTALLATION AT LOW TEMPERATURES

Impact resistance
tested to EN 1451 at -10 °C ❄️

CHEMICAL RESISTANCE

Resistant to acids and alkalis ranging from pH 2 to pH 12.

FACTORY STANDARD

Pipes and fittings tested to EN 1451-1

DIAMETER RANGE

32 – 160 mm

PIPE LENGTHS

DN/OD 32-50: 0.15, 0.25, 0.50, 1.0, 1.5, 2.0 meters

DN/OD 75-160: 0.15, 0.25, 0.50, 1.0, 1.5, 2.0, 2.65 meters

UV RESISTANCE

High UV resistance - outdoor storage up to 2 years if stored correctly (please see Master3Plus Installation Guidelines).

RIGIDITY

Minimum pipe stiffness class
SN4 (≥ 4.0 kN/m²) S16 fittings

COLOR

Outer layer RAL9011 graphite black

Inner layer RAL9003 signal white

Designation	Unit	Value	Standard
Average density	kg/dm ³	1.2	EN ISO 1183
Modulus of elasticity	MPa	> 2400 - 3100	ISO 178
Linear expansion	mm / (m.K)	0.09	
Vacuum tightness	bar	-0.8	SKZ test report no. 225137

APPLICATION AREAS

STANDARD APPLICATION AREAS

Master3Plus soil and waste pipe systems are mainly utilized for hot water resistant drainage pipes for domestic and industrial black-, grey- and rainwater.

Within buildings, Master3Plus can be applied as:

- **Single and group connecting pipes**
- **Downpipes**
- **Collecting lines**
- **Bypass lines**
- **Ventilation lines**
- **Internal rainwater pipes with up to 5 meters of backwater height**

SPECIAL APPLICATIONS

In the case of requirements for oil resistance, the EPDM sealing ring is to be exchanged for an NBR sealing ring.

- **Ventilation systems for commercial and residential buildings**
- **Central vacuuming systems**
- **Transport of chemically aggressive wastewater ranging from pH 2 to pH 12.**

COMPATIBILITY

The dimensions of PIPELIFE Master3Plus pipes and fittings comply with EN 1451-1 and can be combined with other products that comply with this standard.

DO NOT USE MASTER3PLUS FOR

- **External applications (e.g. outdoor rainwater downpipes)**
- **Conveying wastewater containing petrol or benzene**
- **Environmental temperatures exceeding 100 °C**
- **Disposal lines in chemical plants**
- **Indoor rainwater pipes with more than 5 meters of backwater height**



ACOUSTIC PERFORMANCE

SOUND INSULATION

The requirements for acoustic insulation are regulated via various local norms that may vary from market to market. Please turn to your local Pipelife contact for more details on the respective regulations applicable to you.

Standards and regulations should be taken into consideration already during the planning stage. As an example: Walls with sanitary installations should not connect to bedrooms.

Generally, drainage pipes must not be installed in rooms that are to be protected from noise and

must be separated from solid walls with structure-borne sound insulation.

When fastening drainage pipes without structure-borne sound insulation, the mass per unit area of the wall should be at least 350 kg/m².

Domestic installations must be arranged and designed in a way that noise levels resulting from the operation of these installations from other units in use do not exceed the value specified in the table. System noise levels may be 5 dB(A) higher in ancillary rooms.

	Minimum requirement	Increased sound insulation
Type of noise	$L_{AF, max, nT}$ in dB(A)	$L_{AF, max, nT}$ in dB(A)
Short-term, fluctuating noise (e.g. WC flushing)	≤ 30	≤ 25

Table 1: Example of sound insulation requirements according to ÖNORM B 8115-2.

The technical equipment in buildings assigned exclusively to the respective unit in use is excluded from this requirement.

Increased sound insulation during the operation of technical equipment in buildings is given if the permissible A-weighted system noise level is lower by at least 5 dB(A), which corresponds to 25 dB(A), and this is also maintained within the unit of use.

Increased sound insulation of a building must be specified by the client before the start of the planning work and recorded in the invitation to tender.

In comparison to apartments in other countries, the German VDI guideline 4100:2012 distinguishes 3 sound insulation levels. Higher requirements are marked with the sound insulation levels SSt EB.

The VDI 4100 recommends the following sound insulation values in dB(A) [$L_{AF, max, nT}$] for technical equipment (including both water supply and wastewater installations).



Type of building	SSt I	SSt II	SSt III	SSt EB I	SSt EB II
Multi-family dwellings	≤ 30	≤ 27	≤ 24	≤ 35	≤ 30
Single family semi-detached houses Single-family terraced houses	≤ 30	≤ 25	≤ 22	≤ 35	≤ 30

Table 2: Recommended sound insulation values according to VDI 4100.

According to DIN 4109-1:2018, the maximum permissible sound pressure level in rooms requiring external protection must not exceed the values in the following table.

	Living rooms and bedrooms	Classrooms and workrooms
Type of noise	$L_{AF, max, n}$ in dB(A)	$L_{AF, max, n}$ in dB(A)
Short-term, fluctuating noise (e.g. WC flushing)	≤ 30	≤ 25

Table 3: Maximum sound levels to din 4109-1 for rooms requiring external protection.

SOUND MEASUREMENT

Pipelife has subjected Master3Plus acoustic soil and waste pipe systems to extensive standard-compliant sound measurement to DIN EN 14366:2005 and with 4 different fastening clamps in accordance with DIN 4109 and VDI 4100 at the Fraunhofer Institute in Stuttgart. According to the standard, the sound pressure levels in the reception room of the basement are relevant.

The following clamps have been used for testing:

- Pipelife double clamp, sound-absorbing double plastic clamp with rubber insert
- Pipelife single clamp, sound-absorbing single plastic clamp with rubber insert
- Bismat 1000, double steel clamp with rubber insert
- Bismat 2000, standard steel clamp with rubber insert

Installation sound level for Master3Plus installation with an acoustic bottom bend in the "basement rear" measured at Fraunhofer Institute.

BISMAT 1000 CLAMP | PIPELIFE DOUBLE CLAMP

Flow rate l/s	0.5		1.0		2.0		4.0	
	Pipelife	Bismat	Pipelife	Bismat	Pipelife	Bismat	Pipelife	Bismat
Structure borne sound according to DIN EN 14366, L_{scA} [db(A)]	<10	<10	<10	<10	<10	<10	<10	<10
Installation sound level according to DIN 4109, $L_{AFeg,n}$ [db(A)]	<10	<10	<10	<10	<10	<10	12.1	12.6
Installation sound level according to VDI 4100, $L_{AFeg,nT}$ [db(A)]	<10	<10	<10	<10	<10	<10	<10	<10

BISMAT 2000 CLAMP | PIPELIFE SINGLE CLAMP

Flow rate l/s	0.5		1.0		2.0		4.0	
	Pipelife	Bismat	Pipelife	Bismat	Pipelife	Bismat	Pipelife	Bismat
Structure-borne sound according to DIN EN 14366, L_{scA} [db(A)]	<10	<10	<10	11.6	10.6	13.4	14.8	18.0
Installation sound level according to DIN 4109, $L_{AFeg,n}$ [db(A)]	<10	11.4	12	13.8	15.0	16.2	19.2	20.8
Installation sound level according to VDI 4100, $L_{AFeg,nT}$ [db(A)]	<10	<10	<10	10.3	11.5	12.7	15.7	17.2

Table 4: Measuring results of Master3Plus at the Fraunhofer Institute, Stuttgart, Germany.

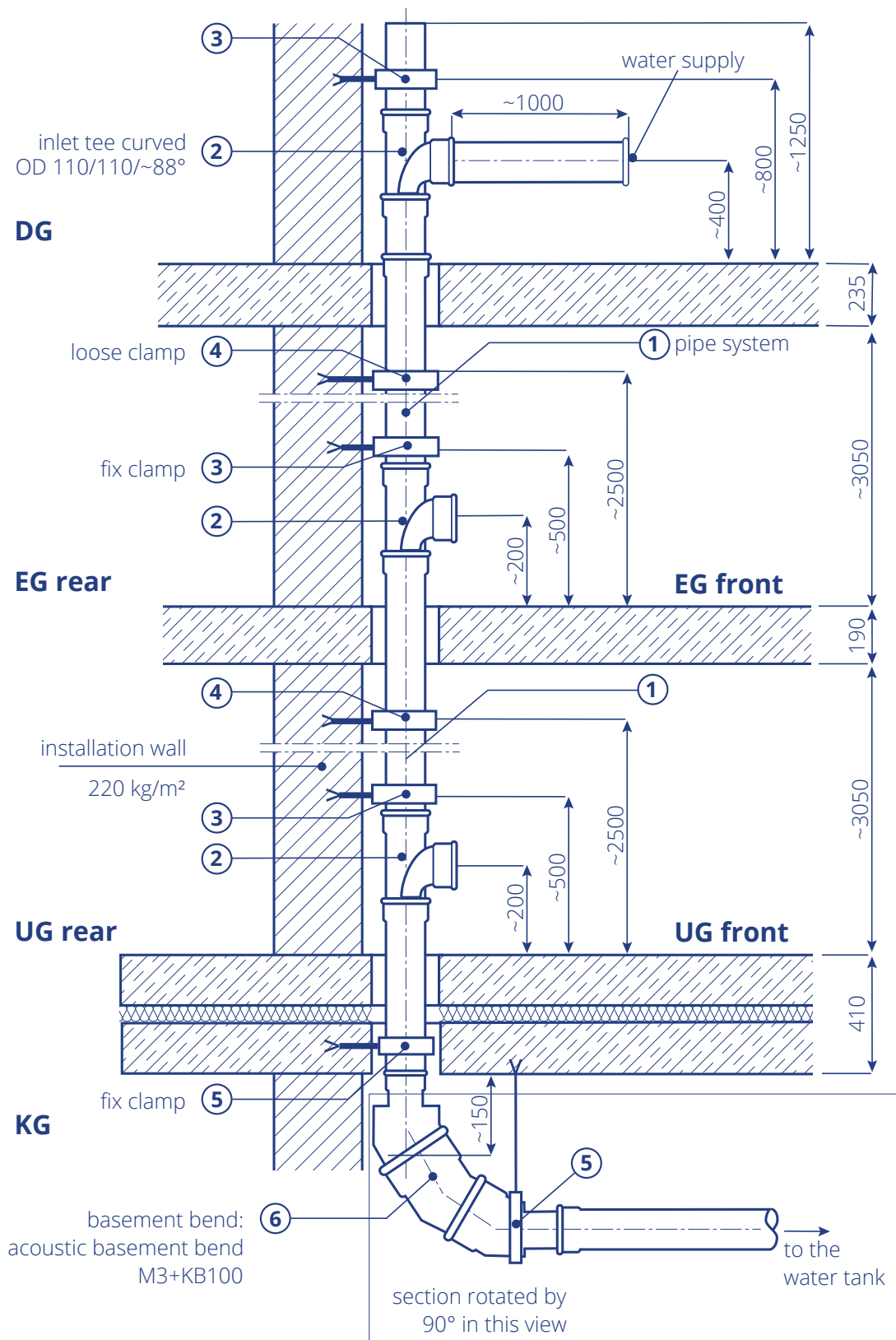

Figure 1: Installation diagram of the sound measurements for the Master3Plus system at the Fraunhofer Institute in Stuttgart (not to scale, dimensions in mm).

FIRE SAFETY

FIRE CLASSIFICATION

Master3Plus has been classified as a B2 flammable material, according to DIN 4102.

FIRE PROTECTION WITH FIRESTOP COLLARS AND WRAPS

Pipe systems and other installations that run through walls and ceilings can compromise fire protection measures. To ensure necessary fire safety precautions are fulfilled, such structures need to, for example, be sealed or encased to provide adequate fire resistance and therefore prevent fire and smoke from progressing. The method and scope of measures are usually defined by national regulations.

In Austria, for example, the specifications for fire protection Guideline 2 of the Institute of Construction (OIB) must be complied with. The “technical guideline for preventive fire protection” (TRVB) sets the requirements for fire resistance and thus the principal implementation possibilities of such measures regarding pipe installations through walls and ceilings.

The installation of soil and waste pipes made from flammable materials in garages, basements and similar spaces is permitted under the following terms:

- The pipe system is made from polyethylene (PE) or polypropylene (PP). Note: PVC cleanouts are permissible but must not exceed the minimum number required.
- The pipe system only serves apartments and respective operating units.
- The necessary encasing can also be implemented as section insulation as long as the measure has been approved in a report by an accredited authority.
- Installations outside basements or garages must be made in service ducts and shafts.

Therefore, and in accordance with this regulation, Master3Plus soil and waste pipe systems may also be used in basements and underground garages.

The openings for installations in partition walls and/or ceilings that form fire partitions must be closed by suitable measures (e.g., bulkheading or cladding) and in such a way that the fire resistance period of the component is not impaired or the transmission of smoke and fire over the time of the required fire resistance period is effectively contained.

If fire safety measures are required for plastic pipelines, fire protection collars or wraps can be used. A multitude of fire collars and wraps have been approved for use with Master3Plus.

For instance, the following:

- Hensotherm® RM30/RM50 and 7KS
- Promat PROMASTOP FC3/FC6
- Hilti CFS
- Air Fire Tech RORCOL V30/V60

WALL DUCTS WITH FIRE COLLARS OR WRAPS

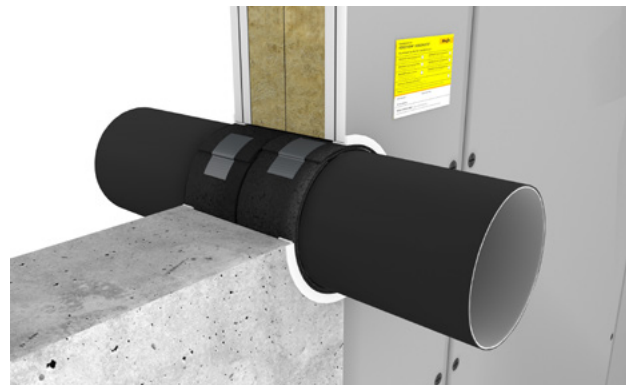
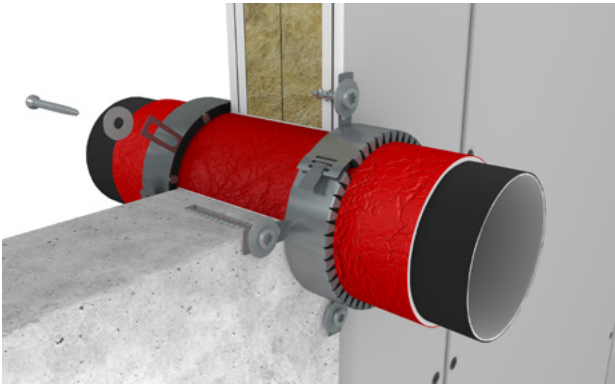

Fire collars or wraps must be installed on both sides of a Master3Plus pipe that leads through a fire compartment wall.

CEILING DUCTS WITH FIRE COLLARS AND WRAPS

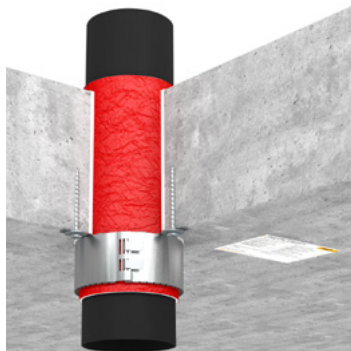
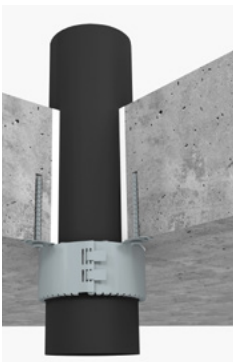

A fire collar or wrap must be applied to a Master3Plus pipe on the ceiling-side of a fire compartment.

SHAFT DUCTS WITH FIRE WRAP 7KS100

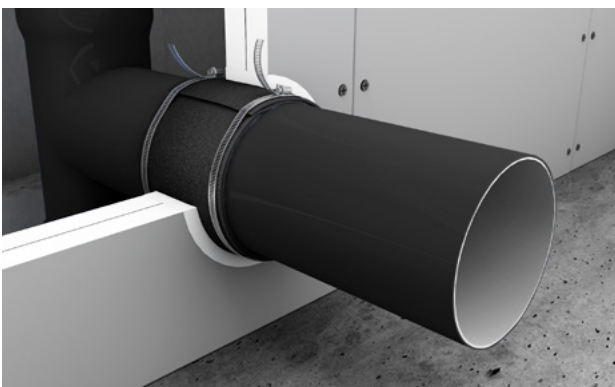

An appropriate number of layers of 100 mm Hensotherm 7KS fire wrap must be applied around Master3Plus soil and waste pipes that run through shaft walls which are planked on one side.

Please note: For each method and product used, the design, planning and application of fire collars and wraps must comply with the specifications and guidelines of the respective manufacturer.

PRODUCT OVERVIEW

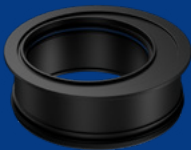

MASTER3PLUS PIPE

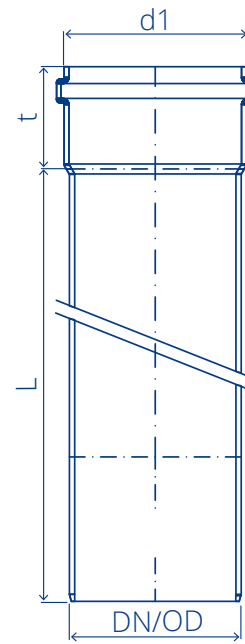

DN/OD	32	40	50	75	90	110	125	160
s1	1.8	1.8	2.0	2.1	2.5	3.0	3.5	4.4
d1	43.0	54.2	64.2	89.4	105.4	127.8	145.5	183.9
t	45	52	52	56	58	62	68	77

L (mm)	Weight (kg/pc.)							
150	0.04	0.06	0.07	0.13	0.20	0.29	0.40	0.69
250	0.06	0.08	0.10	0.19	0.29	0.41	0.57	0.96
500	0.12	0.15	0.19	0.33	0.50	0.72	0.98	1.63
1000	0.22	0.28	0.35	0.63	0.95	1.34	1.81	2.96
1500	0.32	0.41	0.51	0.92	1.39	1.96	2.64	4.30
2000	0.42	0.54	0.68	1.21	1.82	2.57	3.47	5.63
2650	-	-	-	1.59	2.38	3.37	4.54	7.37

MASTER3PLUS BEND

$\alpha = 15^\circ$

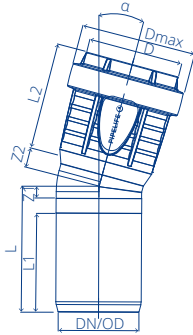

DN/OD	DN	D	DMAX	L1	L2	L	Z1	Z2	KG/PCS	CODE
32	30	33	41.6	30	44.9	46	9	9	0.02	M3-B30/15
40	40	41.1	53.3	46.5	50.55	59	5.5	9	0.04	M3-B40/15
50	50	51	63.3	47	51.15	60	6	10	0.05	M3-B50/15
75	70	76.1	89.1	53	54.75	68	8	12	0.10	M3-B70/15
90	90	91.15	105.35	55	56.5	72	10	14	0.15	M3-B90/15
110	100	111.3	127	59	60.55	76	10	15	0.24	M3-B100/15
125	125	126.3	144.85	65	66.5	88	16	22	0.37	M3-B125/15
160	150	161.5	183.4	74	75.5	95	14	21	0.65	M3-B150/15

$\alpha = 30^\circ$

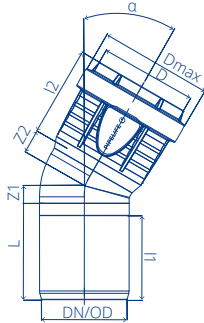

DN/OD	DN	D	DMAX	L1	L2	L	Z1	Z2	KG/PCS	CODE
32	30	33	41.6	30	44.9	47	10	10	0.02	M3-B30/30
40	40	41.1	53.3	46.5	50.55	62	8.5	12	0.04	M3-B40/30
50	50	51	63.3	47	51.15	64	10	13	0.05	M3-B50/30
75	70	76.1	89.1	53	54.75	74	14	18	0.11	M3-B70/30
90	90	91.15	105.35	55	56.5	78	16	20	0.16	M3-B90/30
110	100	111.3	127	59	60.55	84	18	23	0.27	M3-B100/30
125	125	126.3	144.85	65	66.5	96	24	30	0.41	M3-B125/30
160	150	161.5	183.4	74	75.5	106	25	32	0.72	M3-B150/30

$\alpha = 45^\circ$

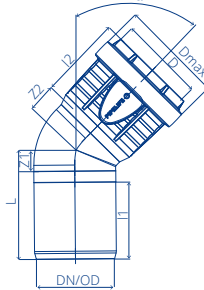

DN/OD	DN	D	DMAX	L1	L2	L	Z1	Z2	KG/PCS	CODE
32	30	33	41.6	30	44.9	48	11	14	0.02	M3-B30/45
40	40	41.1	53.3	46.5	50.55	65	11.5	15	0.04	M3-B40/45
50	50	51	63.3	47	51.15	67	13	17	0.06	M3-B50/45
75	70	76.1	89.1	53	54.75	79	19	23	0.12	M3-B70/45
90	90	91.15	105.35	55	56.5	85	23	27	0.18	M3-B90/45
110	100	111.3	127	59	60.55	92	26	31	0.29	M3-B100/45
125	125	126.3	144.85	65	66.5	105	33	39	0.43	M3-B125/45
160	150	161.5	183.4	69	75.5	114	38	45	0.80	M3-B150/45

$\alpha = 67,5^\circ$

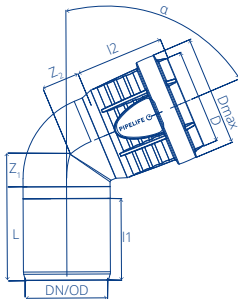

DN/OD	DN	D	DMAX	L1	L2	L	Z1	Z2	KG/PCS	CODE
32	30	33	41.6	30	44.9	55	18	19	0.02	M3-B30/67
40	40	41.1	53.3	46	50.55	70	17	20	0.05	M3-B40/67
50	50	51	63.3	47	51.15	74	20	24	0.06	M3-B50/67
75	70	76.1	89.1	53	54.75	89	29	33	0.13	M3-B70/67
90	90	91.15	105.35	55	56.5	96	34	39	0.20	M3-B90/67
110	100	111.3	127	59	60.55	106	40	45	0.32	M3-B100/67

$\alpha = 87,5^\circ$

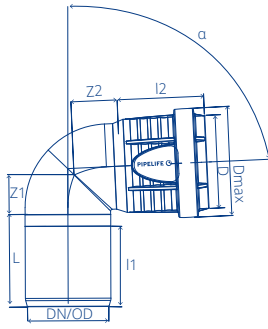

DN/OD	DN	D	DMAX	L1	L2	L	Z1	Z2	KG/PCS	CODE
32	30	33	41.6	30	44.9	62	25	24	0.02	M3-B30/87
40	40	41.1	53.3	46	50.55	76	23	26	0.05	M3-B40/87
50	50	51	63.3	47	51.15	81	27	30	0.06	M3-B50/87
75	70	76.1	89.1	53	54.75	101	41	45	0.14	M3-B70/87
90	90	91.15	105.35	55	56.5	110	48	53	0.22	M3-B90/87
110	100	111.3	127	59	60.55	124	58	63	0.36	M3-B100/87
125	125	126.3	144.85	65	66.5	138	66	72	0.53	M3-B125/87
160	150	161.5	183.4	74	75.5	162	81	88	0.97	M3-B150/87

$\alpha = 45^\circ AS$

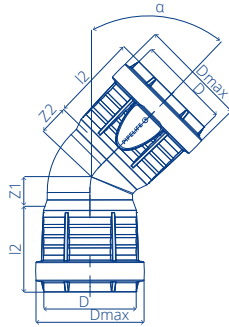

DN/OD	DN	D	D1	D2	DMAX	L2	L3	L	Z1	Z2	KG/PCS	CODE
40	40	41.1	41.1	53.3	53.3	50.55	50.55	65	11.5	15	0.05	M3-BA40/45
50	50	51	51	63.3	63.3	51.15	51.15	67	13	17	0.06	M3-BA50/45
75	70	76.1	76.1	89.1	89.1	54.75	54.75	79	19	23	0.13	M3-BA70/45
90	90	91.15	91.15	105.35	105.35	56.5	56.5	85	23	27	0.20	M3-BA90/45
110	100	111.3	111.3	127	127	60.55	60.55	92	26	31	0.31	M3-BA100/45
125	125	126.3	126.3	144.85	144.85	66.5	66.5	105	33	39	0.47	M3-BA125/45

$\alpha = 87.5^\circ AS$

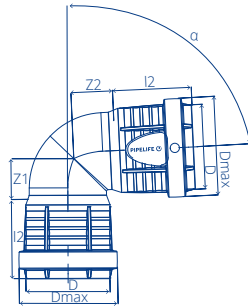

DN/OD	DN	D	D1	D2	DMAX	L2	L3	L	Z1	Z2	KG/PCS	CODE
40	40	41.1	41.1	53.3	53.3	50.55	50.55	76	23	26	0.05	M3-BA40/87
50	50	51	51	63.3	63.3	51.15	51.15	81	27	30	0.07	M3-BA50/87
75	70	76.1	76.1	89.1	89.1	54.75	54.75	101	41	45	0.15	M3-BA70/87
90	90	91.15	91.15	105.35	105.35	56.5	56.5	110	48	53	0.23	M3-BA90/87
110	100	111.3	111.3	127	127	60.55	60.55	124	58	63	0.37	M3-BA100/87
125	125	126.3	126.3	144.85	144.85	66.5	66.5	138	66	72	0.56	M3-BA125/87

Long bend $\alpha = 87.5^\circ$

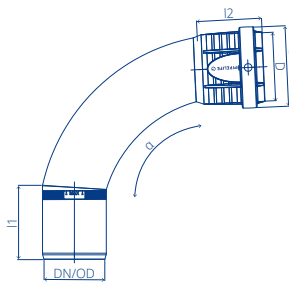

DN/OD	DN	D	DMAX	L1	L2	L	Z1	Z2	KG/PCS	CODE
50	50	51	63.3	47	51.15	81	27	30	0.00	M3-BL50/87
75	70	76.1	89.1	53	54.75	101	41	45	0.00	M3-BL70/87
110	100	111.3	127	59	60.55	124	58	63	0.00	M3-BL100/87

Long bend $\alpha = 87.5^\circ AS$

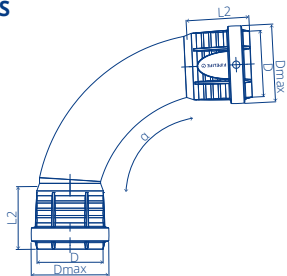

DN/OD	DN	D	D1	D2	DMAX	L2	L3	L	Z1	Z2	KG/PCS	CODE
50	50	51	51	63.3	63.3	51.15	51.15	81	27	30	0.00	M3-BLA50/87
75	70	76.1	76.1	89.1	89.1	54.75	54.75	101	41	45	0.00	M3-BLA70/87
110	100	111.3	111.3	127	127	60.55	60.55	124	58	63	0.00	M3-BLA100/87

MASTER3PLUS BRANCH

$\alpha = 45^\circ$

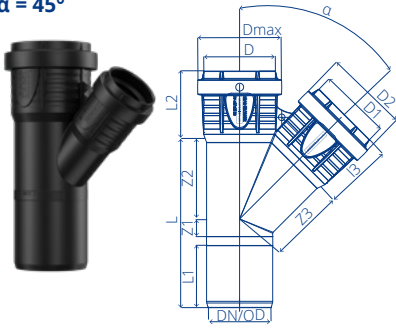

DN/OD	DN	D	D1	D2	DMAX	L1	L2	L3	L	Z1	Z2	Z3	KG/PCS	CODE
32/32	30	33	33	41.6	41.6	30	44.9	44.9	47	10	40	35	0.03	M3-EA30/30/45
40/32	40	41.1	33	41.6	53.3	90	50.55	44.9	103	6	44	43	0.06	M3-EA40/30/45
40/40	40	41.1	41.1	53.3	53.3	95	50.55	50.55	114	12	49	49	0.07	M3-EA40/40/45
50/32	50	51	33	41.6	63.3	96	51.15	44.9	103	0	49	53	0.09	M3-EA50/30/45
50/40	50	51	41.1	53.3	63.3	101	51.15	50.55	114	6	55	57	0.09	M3-EA50/40/45
50/50	50	51	51	63.3	63.3	108	51.15	51.15	128	13	61	61	0.10	M3-EA50/50/45
75/50	70	76.1	51	63.3	89.1	129	54.75	51.15	135	-1	75	79	0.19	M3-EA70/50/45
75/75	70	76.1	76.1	89.1	89.1	144	54.75	54.75	170	19	91	91	0.23	M3-EA70/70/45
90/50	90	91.15	51	63.3	105.35	129	56.5	51.15	136	0	80	91	0.24	M3-EA90/50/45
90/75	90	91.15	76.1	89.1	105.35	154	56.5	54.75	172	11	98	102	0.30	M3-EA90/70/45
90/90	90	91.15	91.15	105.35	105.35	165	56.5	56.5	195	23	109	109	0.37	M3-EA90/90/45
110/50	100	111.3	51	63.3	127	151	60.55	51.15	142	-16	92	103	0.35	M3-EA100/50/45
110/75	100	111.3	76.1	89.1	127	167	60.55	54.75	175	1	108	118	0.43	M3-EA100/70/45
110/90	100	111.3	91.15	105.35	127	178	60.55	56.5	197	12	119	123	0.50	M3-EA100/90/45
110/110	100	111.3	111.3	127	127	192	60.55	60.55	225	26	133	133	0.59	M3-EA100/100/45
125/110	125	126.3	111.3	127	144.85	206	66.5	60.55	233	20	142	144	0.77	M3-EA125/100/45
125/125	125	126.3	126.3	144.85	144.85	216	66.5	66.5	254	31	152	152	0.91	M3-EA125/125/45
160/110	150	161.5	111.3	127	183.4	232	75.5	60.55	240	1	158	168	1.15	M3-EA150/100/45
160/125	150	161.5	126.3	144.85	183.4	243	75.5	66.5	263	13	169	177	1.31	M3-EA150/125/45
160/160	150	161.5	161.5	183.4	183.4	266	75.5	75.5	310	37	192	192	1.70	M3-EA150/150/45

$\alpha = 67.5^\circ$

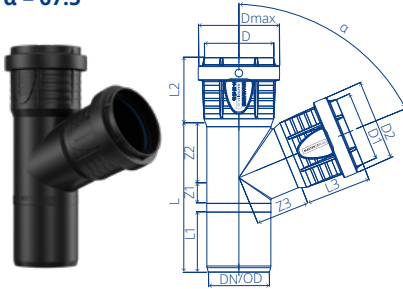

DN/OD	DN	D	D1	D2	DMAX	L1	L2	L3	L	Z1	Z2	Z3	KG/PCS	CODE
50/50	50	51	51	63.3	63.3	90	51.15	51.15	117	20	43	43	0.10	M3-EA50/50/67
110/50	100	111.3	51	63.3	127	116	60.55	51.15	131	8	57	75	0.33	M3-EA100/50/67
110/75	100	111.3	76.1	89.1	127	130	60.55	54.75	158	21	71	80	0.39	M3-EA100/70/67
110/110	100	111.3	111.3	127	127	143	60.55	60.55	191	41	84	84	0.52	M3-EA100/100/67

$\alpha = 87.5^\circ$

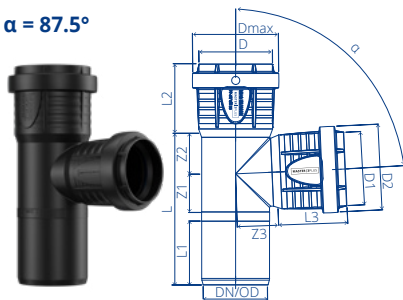

DN/OD	DN	D	D1	D2	DMAX	L1	L2	L3	L	Z1	Z2	Z3	KG/PCS	CODE
32/32	30	33	33	41.6	41.6	30	44.9	44.9	52	15	30	35	0.04	M3-EA30/30/87
40/32	40	41.1	33	41.6	53.3	68	50.55	44.9	93	18	22	26	0.06	M3-EA40/30/87
40/40	40	41.1	41.1	53.3	53.3	71	50.55	50.55	101	23	25	25	0.07	M3-EA40/40/87
50/32	50	51	33	41.6	63.3	70	51.15	44.9	95	18	23	31	0.07	M3-EA50/30/87
50/40	50	51	41.1	53.3	63.3	72	51.15	50.55	102	23	26	30	0.08	M3-EA50/40/87
50/50	50	51	51	63.3	63.3	77	51.15	51.15	112	28	30	30	0.09	M3-EA50/50/87
75/50	70	76.1	51	63.3	89.1	86	54.75	51.15	121	28	32	43	0.16	M3-EA70/50/87
75/75	70	76.1	76.1	89.1	89.1	99	54.75	54.75	147	41	46	46	0.21	M3-EA70/70/87
90/50	90	91.15	51	63.3	105.35	89	56.5	51.15	122	26	33	51	0.22	M3-EA90/50/87
90/75	90	91.15	76.1	89.1	105.35	101	56.5	54.75	147	39	46	52	0.26	M3-EA90/70/87
90/90	90	91.15	91.15	105.35	105.35	99	56.5	56.5	187	81	44	79	0.36	M3-EA90/90/87
110/50	100	111.3	51	63.3	127	94	60.55	51.15	128	27	35	60	0.32	M3-EA100/50/87
110/75	100	111.3	76.1	89.1	127	105	60.55	54.75	151	39	46	62	0.38	M3-EA100/70/87
110/90	100	111.3	91.15	105.35	127	119	60.55	56.5	207	81	60	79	0.50	M3-EA100/90/87
110/110	100	111.3	111.3	127	127	119	60.55	60.55	207	81	60	79	0.54	M3-EA100/100/87
125/125	125	126.3	126.3	144.85	144.85	145	66.5	66.5	225	73	80	80	0.77	M3-EA125/125/87
160/110	150	161.5	111.3	127	183.4	141	75.5	60.55	203	55	67	90	0.99	M3-EA150/100/87
160/160	150	161.5	161.5	183.4	183.4	166	75.5	75.5	253	80	92	92	1.34	M3-EA150/150/87

$\alpha = 45^\circ$ AS

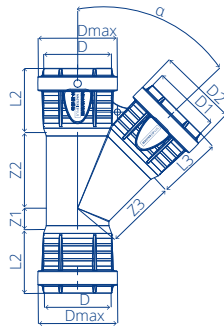

DN/OD	DN	D	D1	D2	DMAX	L2	L3	L	Z1	Z2	Z3	KG/PCS	CODE
40/40	40	41.1	41.1	53.3	53.3	50.55	50.55	165	15	49	49	0.08	M3-EAA40/40/45
50/50	50	51	51	63.3	63.3	51.15	51.15	180	61	61	61	0.11	M3-EAA50/50/45
75/50	70	76.1	51	63.3	89.1	54.75	51.15	200	11	77	80	0.20	M3-EAA70/50/45
75/75	70	76.1	76.1	89.1	89.1	54.75	54.75	224	22	91	91	0.24	M3-EAA70/70/45
90/90	90	91.15	91.15	105.35	105.35	56.5	56.5	251	27	109	109	0.38	M3-EAA90/90/45
110/50	100	111.3	51	63.3	127	60.55	51.15	205	-11	92	103	0.37	M3-EAA100/50/45
110/110	100	111.3	111.3	127	127	60.55	60.55	288	31	133	133	0.62	M3-EAA100/100/45
125/110	125	126.3	111.3	127	144.85	66.5	60.55	305	26	142	144	0.80	M3-EAA125/100/45
125/125	125	126.3	126.3	144.85	144.85	66.5	66.5	306	37	152	152	0.95	M3-EAA125/125/45

$\alpha = 87.5^\circ$ AS

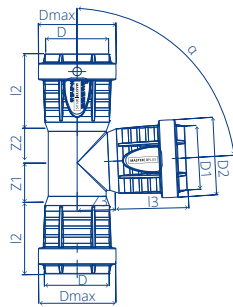

DN/OD	DN	D	D1	D2	DMAX	L2	L3	L	Z1	Z2	Z3	KG/PCS	CODE
40/40	40	41.1	41.1	53.3	53.3	50.55	50.55	152	26	25	25	0.07	M3-EAA40/40/87
50/50	50	51	51	63.3	63.3	51.15	51.15	164	32	30	30	0.10	M3-EAA50/50/87
75/50	70	76.1	51	63.3	89.1	54.75	51.15	174	32	32	43	0.16	M3-EAA70/50/87
75/75	70	76.1	76.1	89.1	89.1	54.75	54.75	201	45	46	46	0.21	M3-EAA70/70/87
90/90	90	91.15	91.15	105.35	105.35	56.5	56.5	219	50	44	79	0.32	M3-EAA90/90/87
110/50	100	111.3	51	63.3	127	60.55	51.15	191	32	35	60	0.34	M3-EAA100/50/87
110/110	100	111.3	111.3	127	127	60.55	60.55	270	86	60	79	0.56	M3-EAA100/100/87
125/110	125	126.3	111.3	127	144.85	66.5	60.55	266	63	66	72	0.66	M3-EAA125/100/87
125/125	125	126.3	126.3	144.85	144.85	66.5	66.5	297	79	80	80	0.81	M3-EAA125/125/87

Corner branch

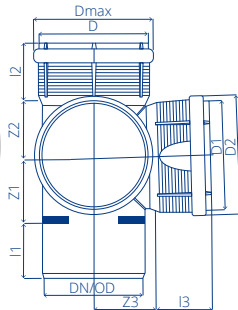

DN/OD	DN	D	D1	D2	DMAX	L1	L2	L3	L	Z1	Z2	Z3	KG/PCS	CODE
110/110	100	111.3	111.3	127	127	61	60.55	60.55	191	59	64	64	0.63	M3-ECK100/100/87

MASTER3PLUS REDUCER

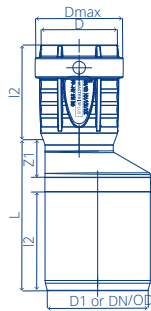

DN/OD	DN	D	D1	D2	DMAX	L1	L2	L	Z1	KG/PCS	CODE
40/32	40	41.1	33	41.6	53.3	47	50.55	66	12	0.03	M3-R40/30
50/32	50	51	33	41.6	63.3	47	51.15	72	18	0.04	M3-R50/30
50/40	50	51	41.1	53.3	63.3	47	51.15	66	12	0.04	M3-R50/40
75/40	70	76.1	41.1	53.3	89.1	53	54.75	87	27	0.08	M3-R70/40
75/50	70	76.1	51	63.3	89.1	54	54.75	81	20	0.08	M3-R70/50
90/50	90	91.15	51	63.3	105.35	55	56.5	91	29	0.11	M3-R90/50
90/75	90	91.15	76.1	89.1	105.35	55	56.5	78	16	0.12	M3-R90/70
110/50	100	111.3	51	63.3	127	59	60.55	109	43	0.17	M3-R100/50
110/75	100	111.3	76.1	89.1	127	59	60.55	93	27	0.19	M3-R100/70
110/90	100	111.3	91.15	105.35	127	59	60.55	85	19	0.19	M3-R100/90
125/110	125	126.3	111.3	127	144.85	64	66.5	89	18	0.28	M3-R125/100
160/125	150	161.5	126.3	144.85	183.4	74	75.5	111	30	0.51	M3-R150/125
160/110	150	161.5	111.3	127	183.4	74	75.5	120	39	0.47	M3-R150/100

MASTER3PLUS LONG SOCKET

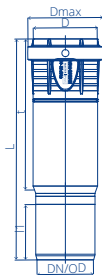

DN/OD	DN	D	DMAX	L1	L	T	KG/PCS	CODE
40	40	41.1	53.3	46	177	118	0.06	M3-L40
50	50	51	63.3	47	187	128	0.08	M3-L50
75	70	76.1	89.1	53.5	205	138	0.16	M3-L70
90	90	91.15	105.35	55	224	154	0.25	M3-L90
110	100	111.3	127	59	244	170	0.37	M3-L100

MASTER3PLUS DOUBLE/PUSH-ON SOCKET

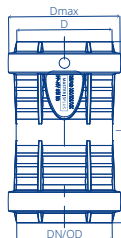

DN/OD	DN	D	DMAX	L	KG/PCS	CODE
32	30	33	41.6	100	0.02	M3-U30
40	40	41.1	53.3	102	0.04	M3-U40
50	50	51	63.3	103	0.05	M3-U50
90	90	91.15	105.35	120	0.15	M3-U90
75	70	76.1	89.1	116	0.10	M3-U70
110	100	111.3	127	129	0.23	M3-U100
125	125	126.3	144.85	140	0.33	M3-U125
160	150	161.5	183.4	159	0.60	M3-U150

MASTER3PLUS SHORT REDUCER

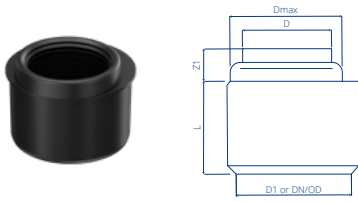

DN/OD	DN	D	D1	D2	DMAX	L	Z1	Z3	KG/PCS	CODE
40/32	40	41.1	33	41.6	53.3	43	15		0.04	M3-R40/30K
50/32	50	51	33	41.6	63.3	47	16		0.05	M3-R50/30K
50/40	50	51	41.1	53.3	63.3	47	16		0.05	M3-R50/40K
75/50	70	76.1	51	63.3	89.1	54	17		0.08	M3-R70/50K
90/50	90	91.15	51	63.3	105.35	66	17		0.11	M3-R90/50K
90/75	90	91.15	76.1	89.1	105.35	61	17		0.12	M3-R90/75K
110/40	100	111.3	41.1	53.3	127	66	18		0.00	M3-R100/40K
110/50	100	111.3	51	63.3	127	66	18		0.16	M3-R100/50K
110/75	100	111.3	76.1	89.1	127	66	19		0.16	M3-R100/70K
110/90	100	111.3	91.15	105.35	127	66	19		0.17	M3-R100/90K
165/110	150	161.5	111.3	127	183.4	89	19		0.43	M3-R150/100K

MASTER3PLUS INTERNAL REDUCER

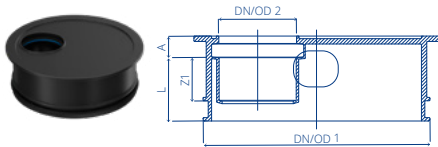

DN/OD	DN	D	D1	D2	DMAX	Z3	KG/PCS	CODE
50/40	50	51	41.1	53.3	63.3		0.00	M3-Ri50/40
90/50	90	91.15	51	63.3	105.35		0.00	M3-Ri90/50
110/40	100	111.3	41.1	53.3	127		0.00	M3-Ri100/40
110/50	100	111.3	51	63.3	127		0.00	M3-Ri100/50
110/75	100	111.3	76.1	89.1	127		0.00	M3-Ri100/70
110/90	100	111.3	91.15	105.35	127		0.00	M3-Ri100/90
160/50	150	161.5	51	63.3	183.4		0.00	M3-Ri150/50
160/110	150	161.5	111.3	127	183.4		0.00	M3-Ri150/100

MASTER3PLUS SOCKET PLUG



DN/OD	L	KG/PCS	CODE
32	33	0.008	M3-M30
40	39	0.010	M3-M40
50	39	0.014	M3-M50
75	39	0.027	M3-M70
90	42	0.041	M3-M90
110	46	0.068	M3-M100
125	50	0.089	M3-M125
160	58	0.174	M3-150

MASTER3PLUS STRAIGHT CONNECTION PIECE

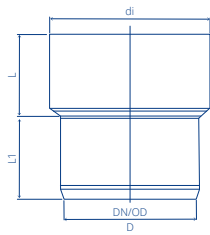

DN/OD	DN	D	DMAX	L1	L	KG/PCS	CODE
32	30	33	41.6	31	32	0.03	M3-S30
40	40	41.1	53.3	32	30	0.02	M3-S40
50	50	51	63.3	29	31	0.03	M3-S50

MASTER3PLUS SIPHON CONNECTION ELBOW

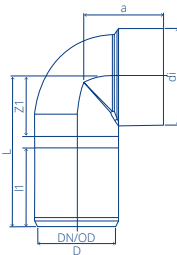

DN/OD	DN	D	DMAX	L	Z1	A/SIPHON	KG/PCS	CODE
32	30	33	41.6	47	25	54	0.02	M3-SW30
40	40	41.1	53.3	88	35	57	0.05	M3-SW40
50	50	51	63.3	90	35	52	0.05	M3-SW50

MASTER3PLUS COMBINATION NIPPLE

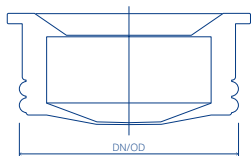

DN/OD	Metal pipe	da	kg/pc.	CODE
32/40/50	28-47	54	0.03	M3-NI5/4/6/4

MASTER3PLUS ACOUSTIC BOTTOM BEND

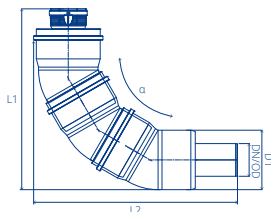

DN/OD	L1	L2	D1	R	CODE
110	608	686	200	400	M3-KB100

MASTER3PLUS CLEANING PIPE

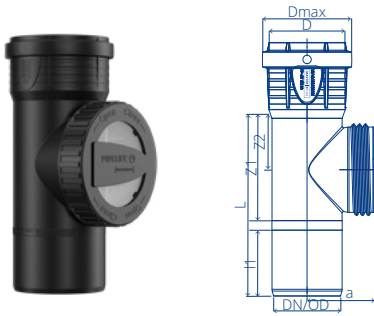

DN/OD	DN	D	DMAX	L1	L2	L	Z1	Z2	KG/PCS	CODE
50	50	51	63.3	47	51.15	130	76	40	0.09	M3-RE50
75	70	76.1	89.1	53	54.75	142	82	42	0.16	M3-RE70
90	90	91.15	105.35	55	56.5	189	127	65	0.28	M3-RE90
110	100	111.3	127	59	60.55	194	128	66	0.41	M3-RE100
125	125	126.3	144.85	65	66.5	225	154	80	0.63	M3-RE125
160	150	161.5	183.4	74	75.5	253	172	92	1.08	M3-RE150

MASTER3PLUS PP CLEANING PIECE

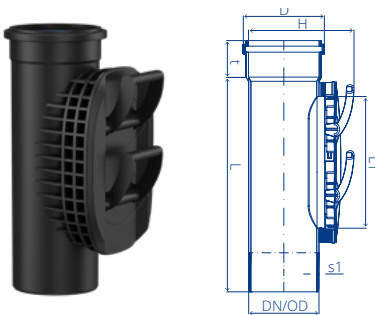

DN/OD	D	L1	L	H	S1	t socket	KG/PCS	CODE
110	129	301	468	196	3.6	65	2.3	PP-KRGK100
125	146	301	474	222	4.0	73	2.5	PP-KGRK125
160	185	301	488	251	5.1	84	3.2	PP-KGRK150

MASTER3PLUS VENTILATION PIPE

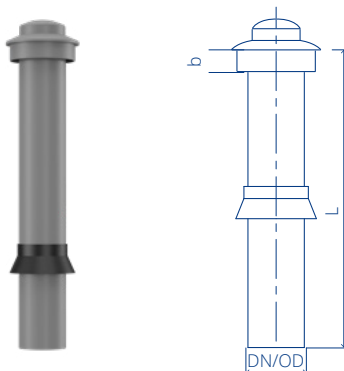

DN/OD	B	L	KG/PCS	CODE
50	-5	670	0.25	KADH50
75	16	667	0.373	KADH75
110	177	751	1.35	KADH100
125	200	1038	1.322	KADH125
160	246	1143	2.374	KADH150



The contents and information contained in this brochure are intended for general marketing purposes only and shall not be relied upon by any person as complete or accurate. In particular, this brochure cannot replace proper expert advice on the characteristics of the products, their usage, suitability for any intended purpose, or the proper processing method. All contributions and illustrations in this brochure are subject to copyright. Unless explicitly otherwise stated, the repetition of content is not permitted. The use of photocopies from this brochure is for private and non-commercial use only. Any duplication or distribution for professional purposes is strictly forbidden. Non-Liability: PIPELIFE has established this brochure to the best of its knowledge. Pipelife cannot accept any liability suffered or incurred by any person resulting from or in connection with any reliance on the content of or the information contained in this brochure. This limitation applies to all loss or damage of any kind, including but not limited to direct or indirect damages, consequential or punitive damages, frustrated expenses, lost profit or loss of business.